

TDM Serious



- ◆ PM motor (DC) - High efficiency and Long life.
- ◆ Protection
  - Impedance protection – Controller and motor will not be damaged when door locked.
  - Over door force detection. – Under HC mode.
- ◆ Continuous stall torque –Motor maintains power at limit position.
- ◆ High-Speed Mode: 8-second 125% torque boost.
- ◆ Three-Speed Opening Mode: Low-High-Low.
- ◆ Quick Controller Setup: Motor direction and parameter switches.
- ◆ Compatible with Mechanical and Electronic (TPE10 Photoelectric Switch) Position Switches.
- ◆ 3 years warranty (Controller and motor are TORMO).

1. DOOR MOTOR ORDERING INFORMATION

1.1. U Type Door Opener (Move Up-Down): Motor with Worm Gear Reducer

Door Motor + Gearbox Model	TP201/600 +WG10	TP251/550 +WG10	TP501/550 +WG10	TP701/550 +WG10	TP902/550 +WG10	TP1002/560 +WG10
Door Motor Model	* TP201/600	TP251/550	TP501/550	TP701/550	TP902/550	TP1002/560
Usage Reference – Max Door Width (mm)	* 2000	2500	3000	3500	4000	4500
Door Controller Model	TDM□□ – P				TDM□□-H	

\* **Maximum Door Width** is reference only. It depended on the door operator reduce ratio, door operator type and door weight.

2. DOOR CONTROLLER ORDERING INFORMATION

TDM		□	□	-	□
		1	2		3
1	Door Open/Close Signal	<b>S</b> – Single Contact <b>D</b> – Dual Contacts <b>V</b> – Dual Contacts plus External DC24V			
2	Voltage Input:	<b>1</b> – AC110V 50/60Hz or DC110V <b>2</b> – AC230V 50/60Hz			
3	Option Code	<b>B</b> – TP Series Permanent Magnet Motor - Eliminates Generator Effect, 1 set of O/C connection wires - for photocell or proximity switch use. <b>C</b> – TP Series Permanent Magnet Motor - Eliminates Generator Effect. <b>H</b> –TP Series Permanent Magnet Motor - Eliminates Generator Effect, for U-type doors - Tt=15sec, Motor TP90~TP100 <b>P</b> – TP Series Permanent Magnet Motor - Eliminates Generator Effect, for U-type doors - Tt=15sec, Motor TP201~TP701			

3. SPECIFICATION and CHARACTERISTICS

● Panel function

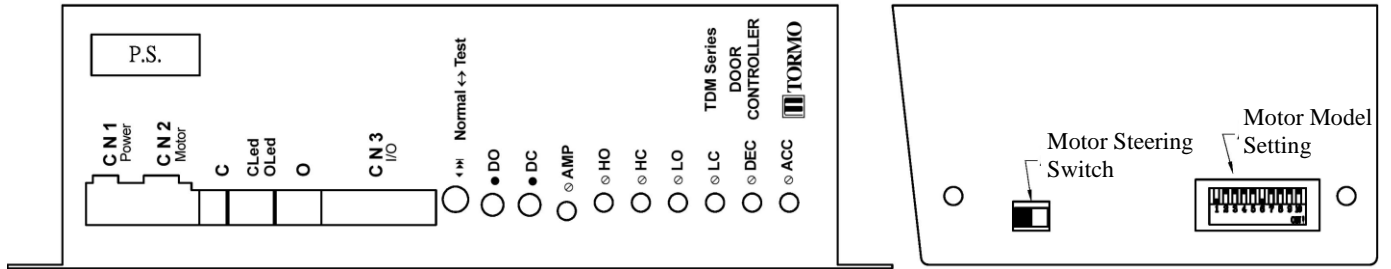

<b>Wiring Installation</b>	CN1	Door Controller Power Input	
	CN2	Motor Power	
	CN3	Control Signal Input/Output	
<b>Operating Modes</b>	Auto↔Manual	Elevator Normal Operation Mode ↔ Manual Testing Mode	
	DO	Manual Open/Close Buttons (TDM <u>S</u> □ Series)	
	DC	Manual Close Button (TDM <u>D</u> □ and TDM <u>V</u> □ Series)	
<b>Adjusting Action Characteristics</b>	HO	High-Speed Door Opening	
	HC	High-Speed Door Closing	
	LO	Low-Speed Door Opening	
	LC	Low-Speed Door Closing	
	ACC	Door Open/Close Acceleration Time	
	DEC	Door Open/Close Deceleration Time	
<b>Motor Model Setup</b>		TP07-06HG10, TP20, TP201/600 TM20, TM201, TM202	1,6 ON All Others Off
		TP22, TP22-1Z011, TP22-TU011, TP08/125VG101, TP08/100VG201, TM28, TM40	2,7 ON All Others Off
		TP25, TP251/550, TP50, TP501/550 TM402, TM50	3,8 ON All Others Off
		TP201/1500, TP70 TM502, TM70	4,9 ON All Others Off
		-	-
<b>Indicators</b>	P.S.	Power Switch	
	AMP	Foreign Object Detection	
	CLed	Door Closing Speed – Bright/Dark: High Speed/Low Speed	
	OLed	Door Opening Speed – Bright/Dark: High Speed/Low Speed	

● Door controller wiring - CN1, CN2, CN3

1). TDMS Series Wiring Diagram

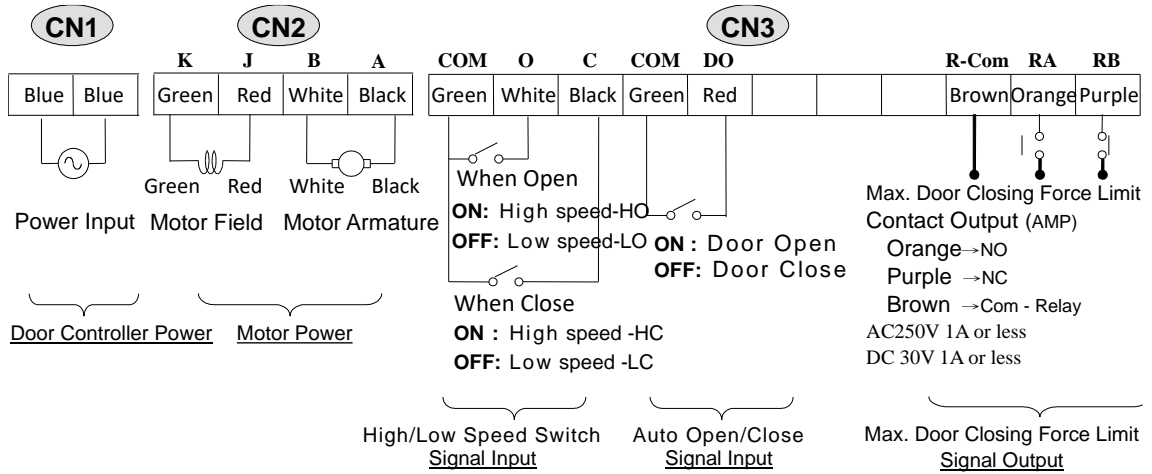

2). TDMD Series Wiring Diagram

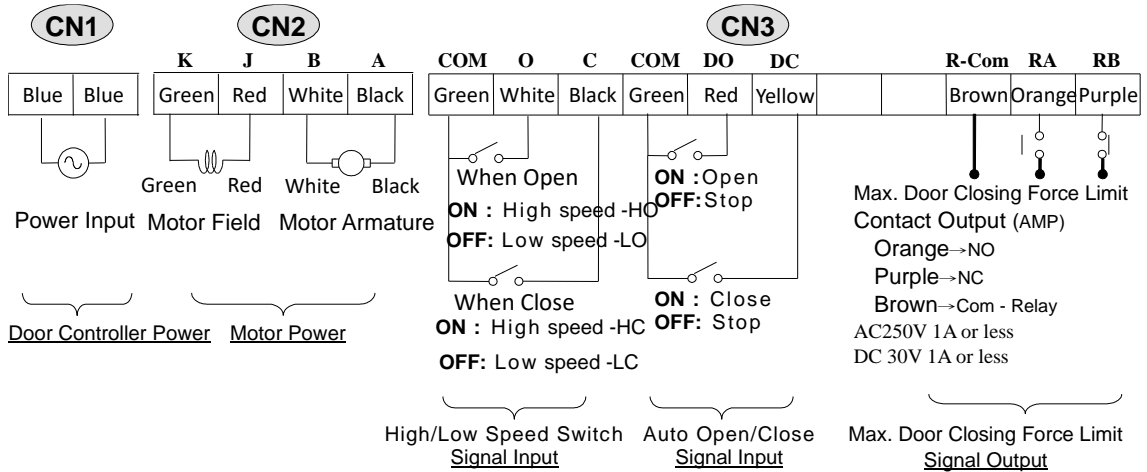

3). TDMV Series Wiring Diagram

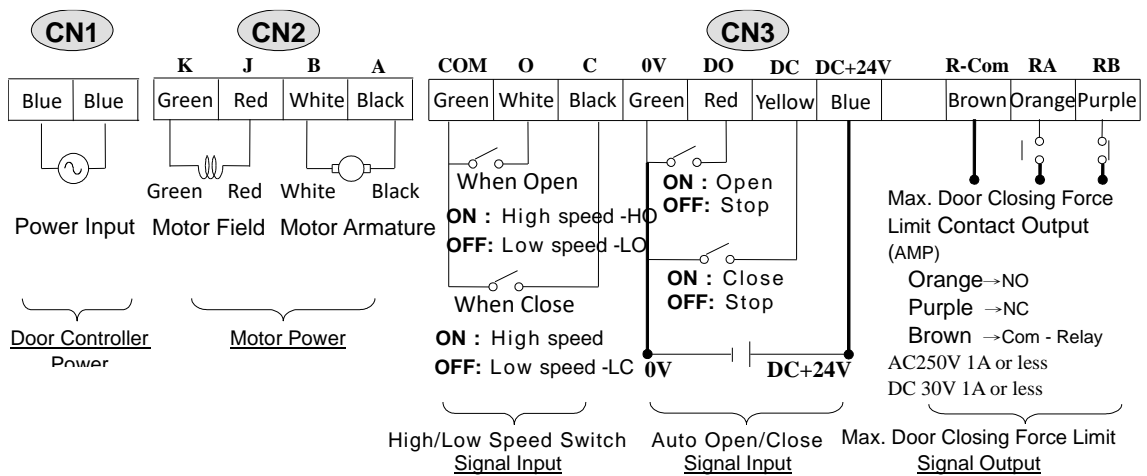

● Door Controller Specifications

Specification	Unit					
Voltage Input Range	Volts	AC110V Series: AC90V~AC110V or DC110V~DC150V				
Output Voltage	Volts	Vab : DC 0~120V Vjk : DC150V				
Control Method		Power Transistor				
Dial Switch Settings		1,6 ON	2,7 ON	3,8 ON	4,9 ON	5,10 ON
Continuous Holding Current (IL)	Amps	0.35	0.5	0.6	0.75	0.95
Continuous Rated Current (IR)	Amps	0.85	1.15	1.5	1.9	2.3
Maximum Current (IT)	Amps	1.1	1.5	1.95	2.45	2.9
Maximum Ambient Temperature	°C	40				
Protection Features		<ul style="list-style-type: none"> <li>● Overcurrent Protection</li> <li>● Foreign Object Detection</li> </ul>				

● Door Controller Dimensions

◆ TDM□1 Series (AC110V)

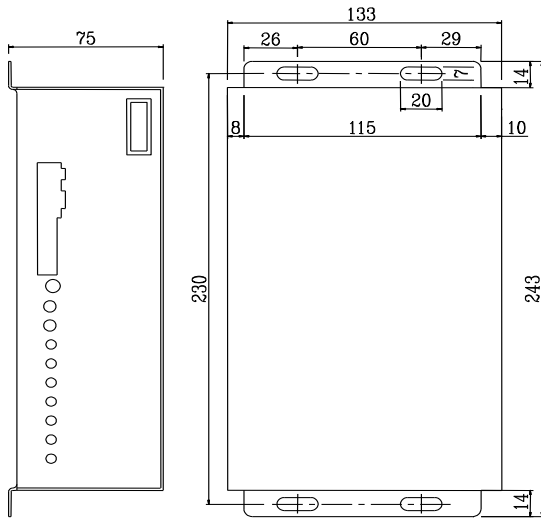

◆ TDM□2 Series (AC230V)

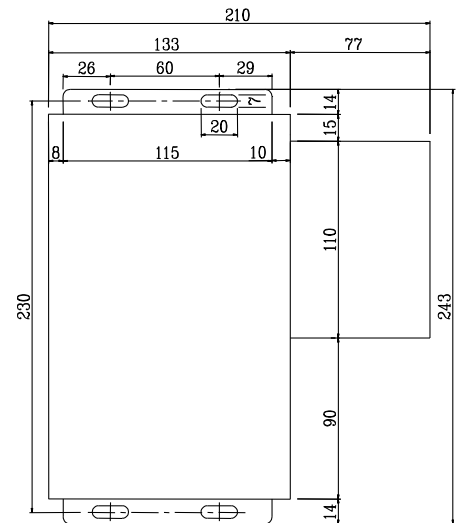

● WORKING CURVE

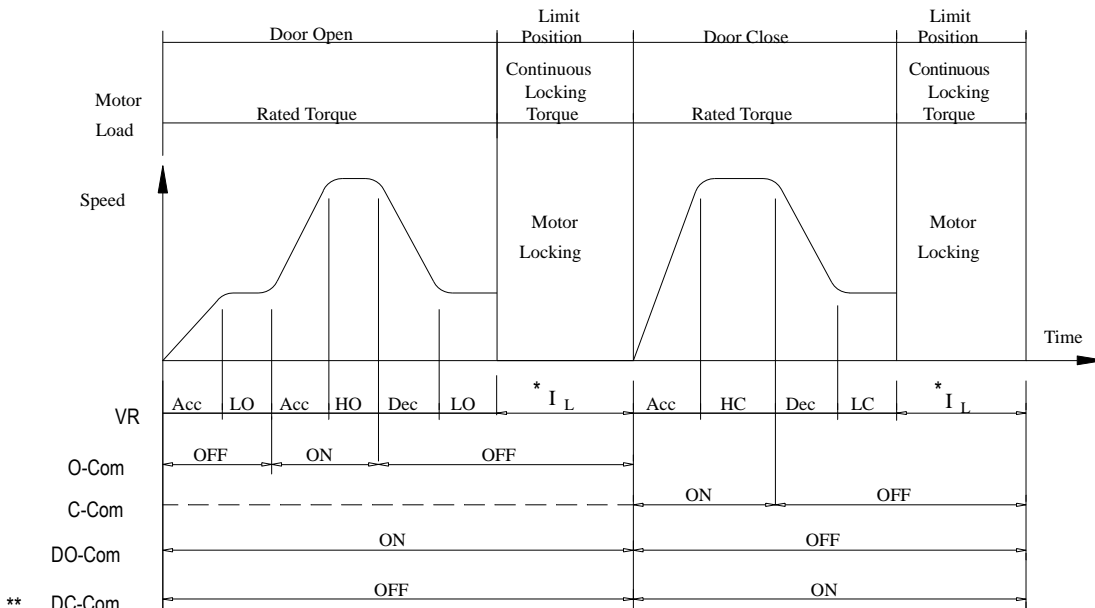

\*  $I_L$  : Continuous Locking Current - Constant  
 \*\* DC-Com: Model TDMD□ and TDMV□ are available

## 4. TECHNICAL DATA

- U Type Door Opener (Move Up-Down): Motor with Worm Gear Reducer

Parameter	Unit	TP201/600 +WG10	TP251/550 +WG10	TP501/550 +WG10	TP701/550 +WG10	TP902/550 +WG10	TP1002/560 +WG10
Gearbox Type / Gear Ratio		Worm Gear Reducer / 10					
Motor Specifications							
Motor Model		TP201/600	TP251/550	TP501/550	TP701/550	TP902/550	TP1002/560
Max. Voltage	Volts	DC90V			DC110V		
Output - Continuous Rating	Watt	60	90	150	200	250	300
Voltage Gradient No Load	V/100rpm	15	16	20	20	20	20
Max. Speed *	rpm	600	550	550	550	550	560
Continuous Locking Torque (TL) *	Kg-cm	4.7	10	13.8	18.7	19.5	25.6
Continuous Locking Current (IL) *	Amps	0.35	0.63	0.63	0.75	0.9	1.4
Rating Torque - Continuous (TR) *	Kg-cm	12	25	33	45	51	67
Rating Current - Continuous (IR) *	Amps	0.85	1.5	1.5	1.9	2.35	3.4
Max. Torque (Tp) **	Kg-cm	34	76	110	170	170	200
Max. Current (Ip) **	Amps	3.2	4.7	5.1	7	7.8	9
Torque Constant (KT) *	Kg-cm/A	11	16	22	24	21	19
Temperature Rise ( $\Delta T$ )	$^{\circ}C$	15	15	15	15	15	15
Armature Resistance (A, B) - Carbon Brushless ***	$\Omega$	10	19	19	14	12	10
Weight (Including Packaging)	Kg	6	9	12	15	16	21
Carbon Brush warranty	Year	20					
Insulation Class	Class	B					
Max. Ambient Temperature	$^{\circ}C$	40					
Motor Protection		IP44 (TENV)					
Voltage Resistance		AC1000V-1min					
Insulation Resistance	M $\Omega$	50					

1). \* Motor characteristics data measured at an ambient temperature of 25 $^{\circ}C$  with the door controller under power supply.

2). \*\* Motor characteristics data measured under no current limiting conditions.

\*\*\* Ambient temperature of 25 $^{\circ}C$

5. Door Motor Dimension

● Worm Gear Motor

◆ TP201/600+WG10

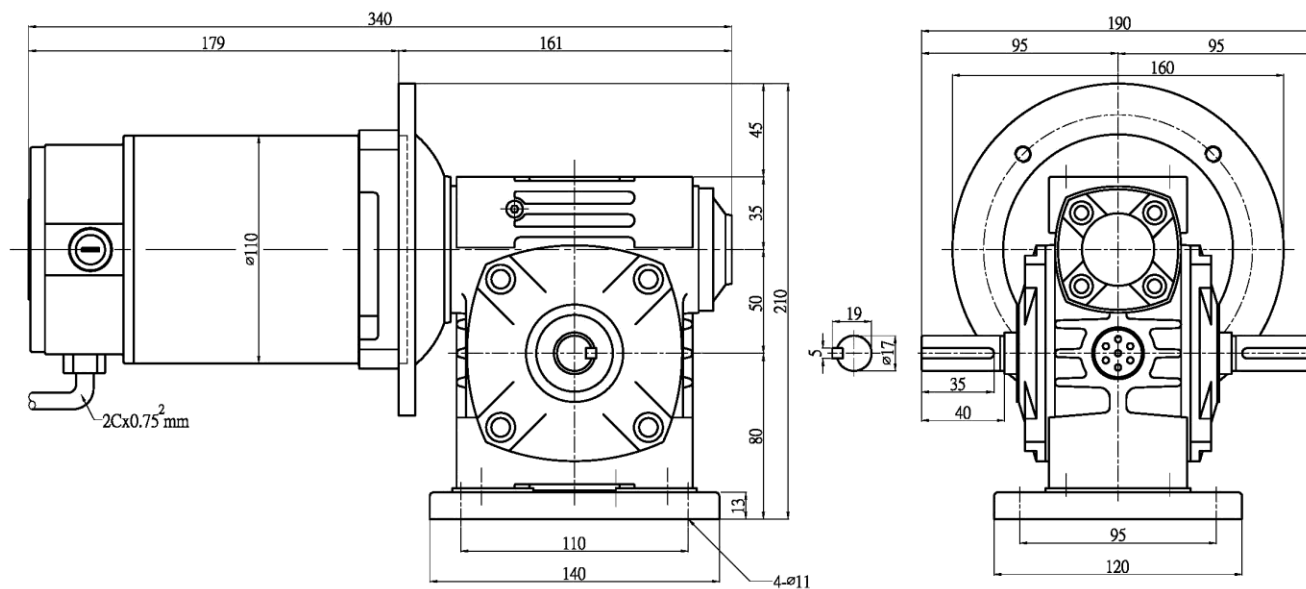

◆ TP251/550+WG10

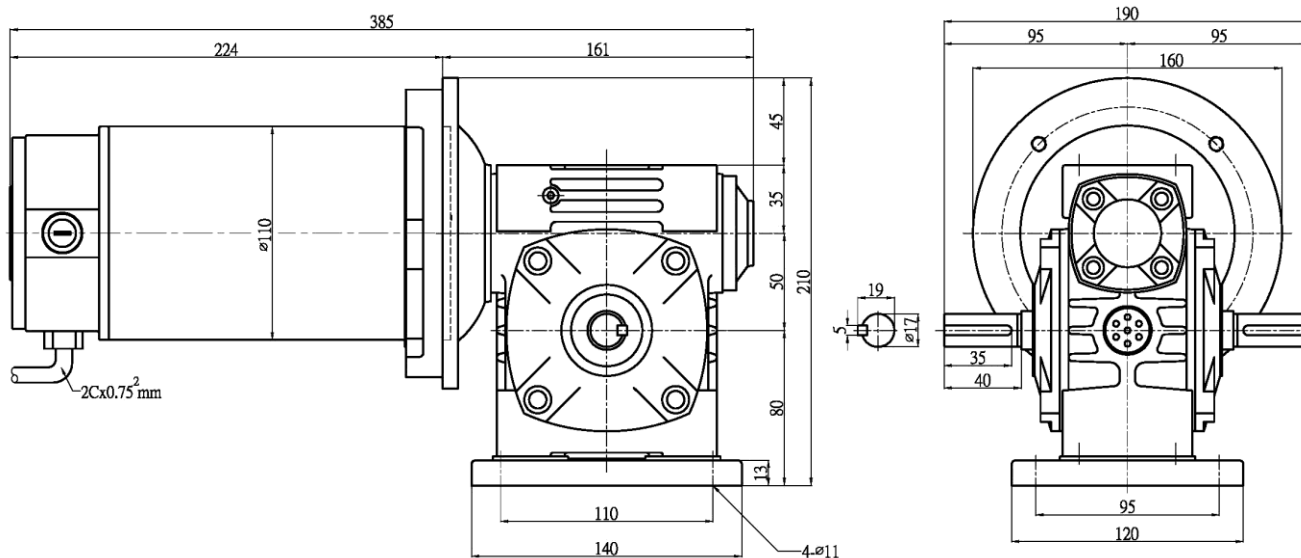

◆ TP501/550+WG10 / TP701/550+WG10

	TP501/550+WG10	TP701/550+WG10
A	376	406
B	215	245

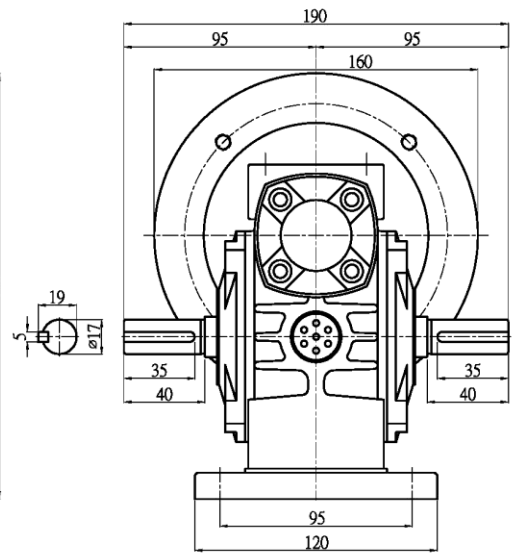
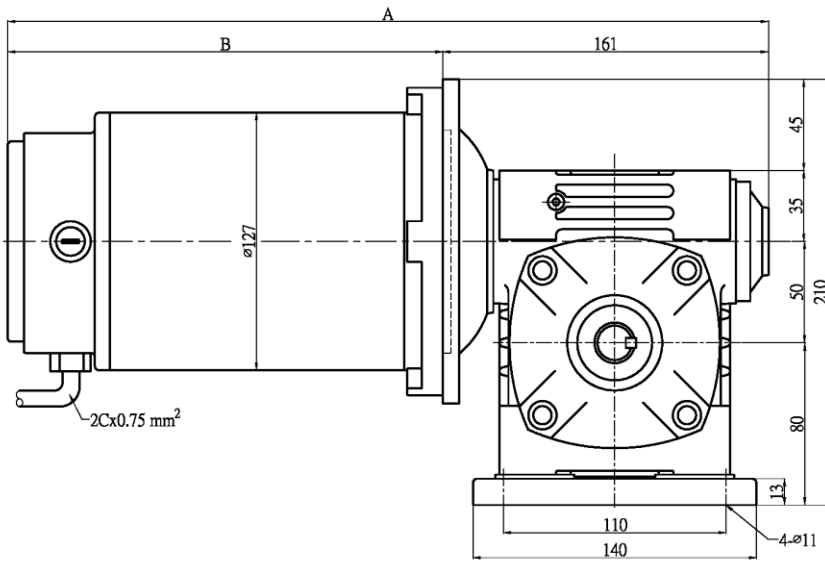

◆ TP902/550+WG10 / TP1002/560+WG10

	TP902/550+WG10	TP1002/560+WG10
A	376	406
B	215	245

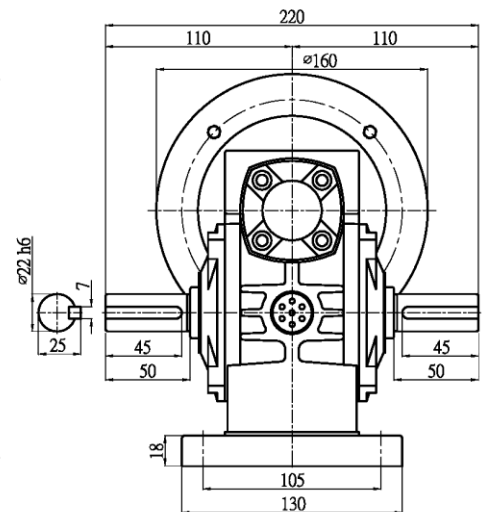
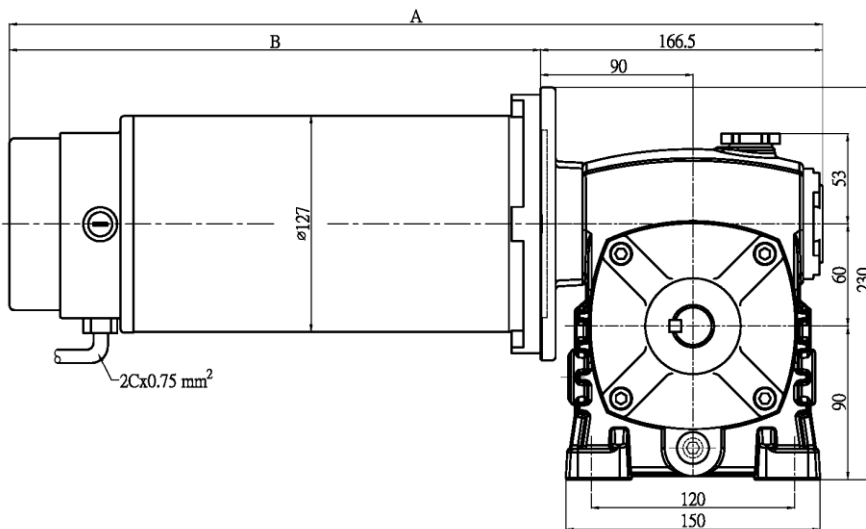

◆ Motor Wiring

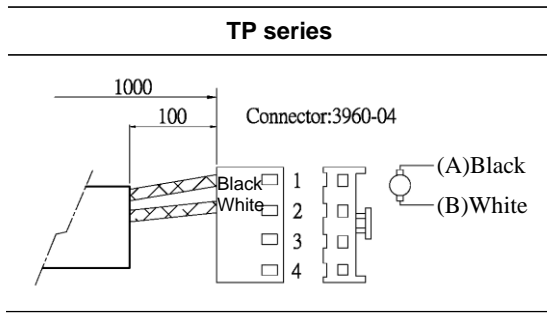

● Motor Accessories - Belt Pulley

**Belt Pulley Specifications**

$\frac{P}{1} \frac{M}{2} \frac{28}{3} - \frac{11}{4}$

- 1: Belt Pulley
- 2: Belt Specifications
- 3: Length (B)
- 4: Tension Belt Width (Only for High Tension)

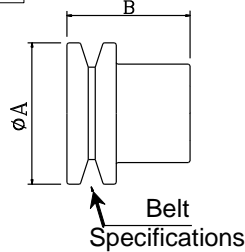

Belt Pulley Model	Belt Specifications	A	B
PA40	A	45	40
PA28	A	50	28
PH28-5	H(High Tension 5mm)	45	28
PH37-5	H(High Tension 5mm)	45	37
PH28-11	H(High Tension 11mm)	50	28
PH40-11	H(High Tension 11mm)	45	40
PK37	K	45	40
PM40	M	45	40
PM28	M	50	28

◆ NOTES

● TM – TP – Motor Comparison Table

Door Motor Model	TP22		TP25	TP50	TP70	TP90	TP100
Door Motor Model	TM20	TM28	TM40	TM50	TM70		
Max. Door Width *	1000 mm		1200 mm	1800 mm	3000 mm	4500 mm	7000 mm
Door Controller Model	TDM□□ – □					TDMS1-H	